

Stage Plot

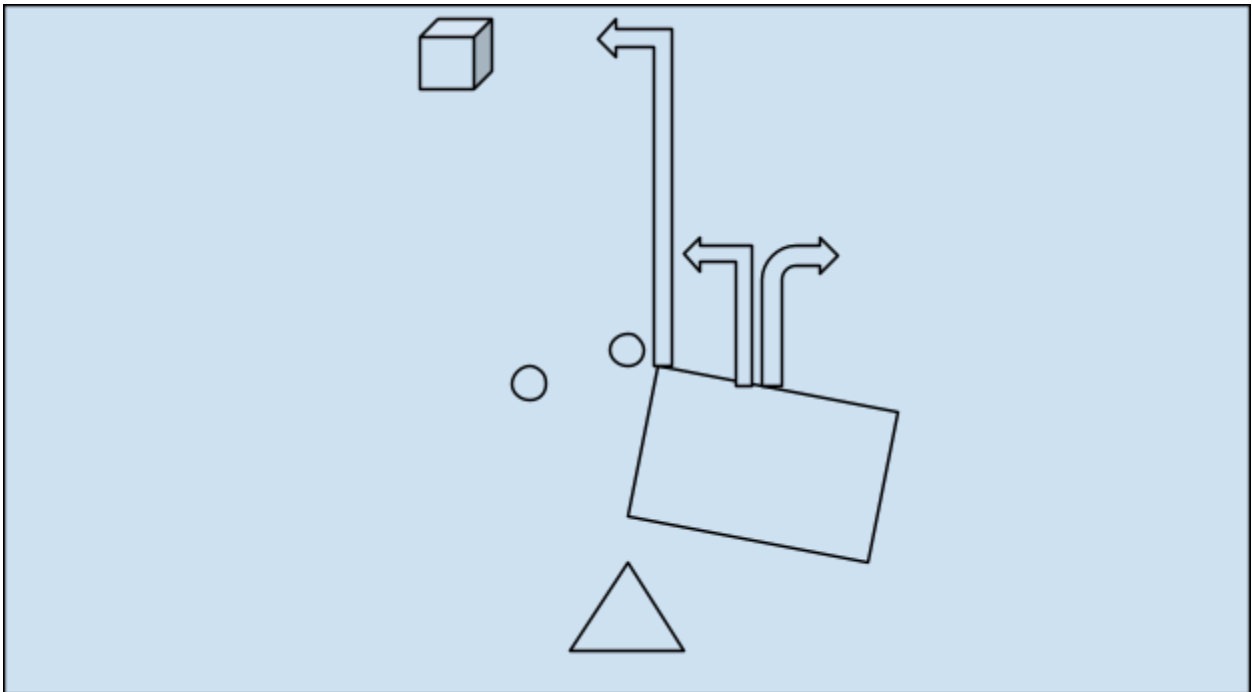

Triangle: I am the triangle

Rectangle: This is my pedal board

Circles: Each represents a center piece of my two microphone stands

Cube: This represents the DI box for mono

Long Arrow: This is my power cord for my pedal board

Short L+R Arrows: These are my lines going out. I can do L+R or mono

Tech Rider

Dylan Thomas Gavin

Description: I loop acoustic guitar and vocals on my pedal board which I send into my Presonus mixer for further level and EQ adjustments. My lead vocals run through a separate microphone into this same Presonus mixer.

I use in ear monitors which plug into my mixer to hear both my pedalboard (looping guitar and vocals) as well as my lead vocal mic. I ultimately output mono or L+R into the house system (mixer or DI box). I don't use a stage monitor because its output will feed into my looping setup.

I will bring: Two vocal microphones (one for looping vocals connected to my pedal board and one for lead vocals), pedal board, mixer, mic stands, cables, guitars, a small bench, IEMs and an extension cord.

I will need: Power and the house sound system.

Note: I can bring a sound system if needed, I have a pair of PAs and an sub.